

HANG DOOR– If **surface mounted hinges** are used, shim the door in the opening leaving 1/8" clearance at the top of the door and equal spaces along each side (but not more than 3/16" at lock edge). Use wedges at the bottom of the door to hold it in place. Carefully align the hinges on a common vertical line then drill through the door with a 1/4" diameter bit, using each hinge as a drilling template. Counterbore the hinge holes from the back side of the door with a 3/8" diameter bit to a depth of 1/2". Use the thru-bolts and grommet nuts supplied with the hinges to hang the door.

If **mortised hinges** are used, screw holes are factory predrilled on doors using standard Tiger Door hinge locations. Use only Tiger Door supplied screws to hang the door– do not use the screws furnished with the hinges.

If **mortised continuous hinges** are used, field drilling of pilot holes will be required. Tiger Door recommends that a minimum of a #12 x 2" sheet metal screw in combination with a 5/32" pilot hole be used for hinge attachment. Shorter or smaller screws may not provide sufficient pullout resistance.

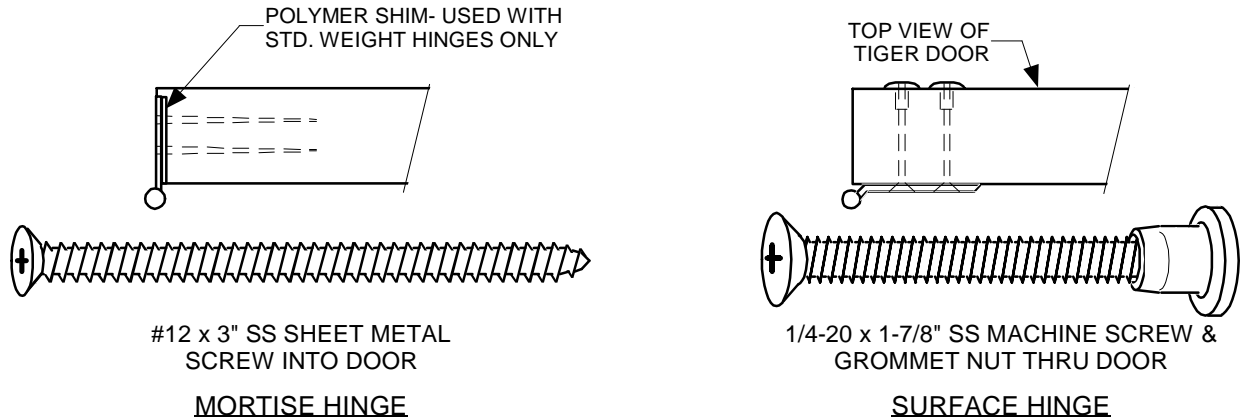

TYPES OF HINGES WITH FASTENERS REQUIRED FOR FRP DOORS

ALL DOORS ARE MACHINED FOR HEAVY WEIGHT HINGES. Polymer shims are pre-installed on the doors when standard weight hinges are to be used. Use one shim underneath each hinge.

FASTENERS - Sheet metal screws with full length threads or through bolts are required for fastening hardware to doors. All closers installed must be installed with through bolts. Self-tapping or combination wood/metal screws shall not be used. Failure to follow these fastener requirements may void the Tiger Door product warranty.

INSTALL BALANCE OF HARDWARE ITEMS at identified reinforcement locations and adjust as necessary for proper door fit and operation. Install threshold, then weatherstripping, only after all else has been completed.

09/12/05